



Morden Hall Contract

Contract 31554

Morden Hall Contract

Contract 31554

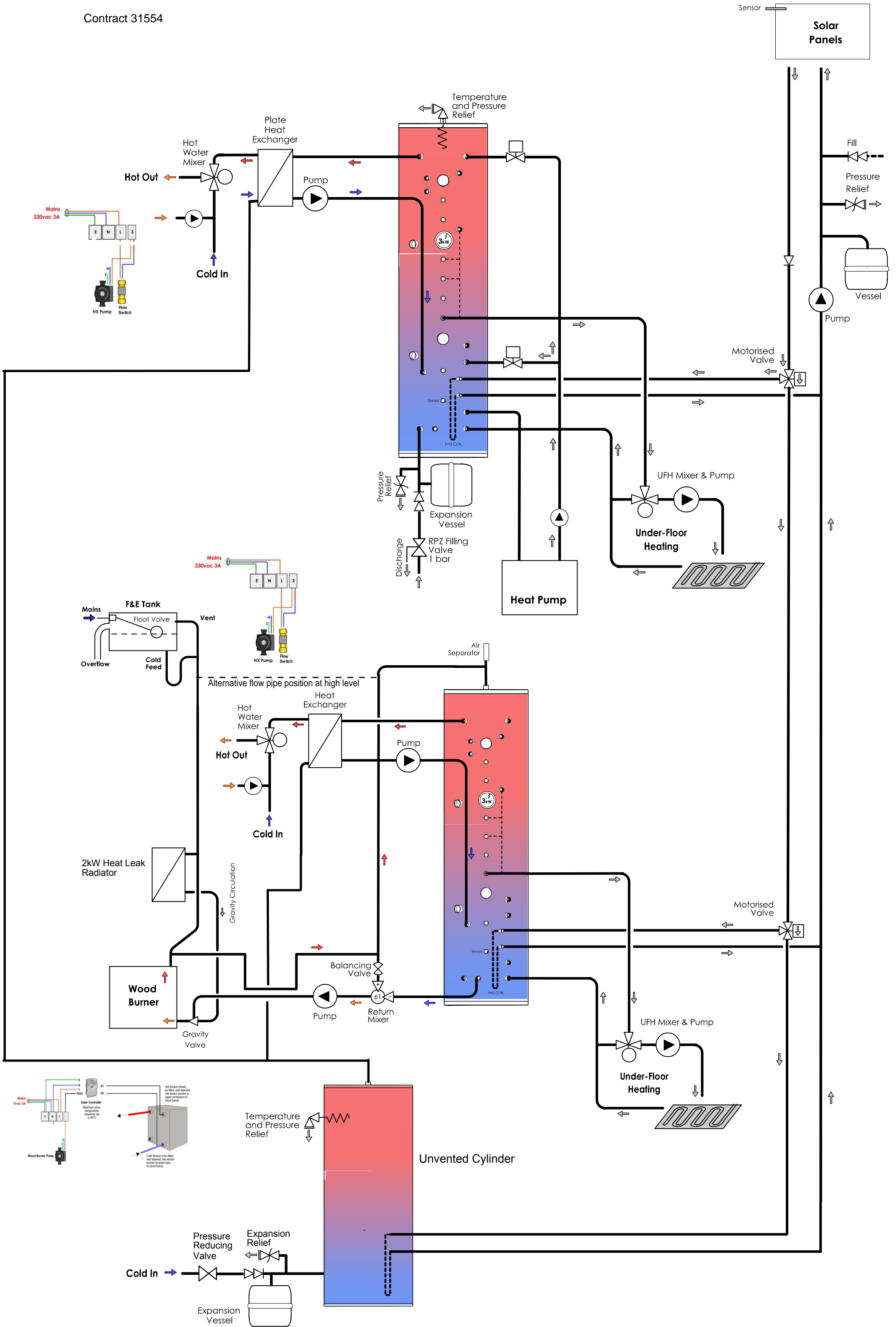

Morden Hall Contract

Contract 31554

SYSTEM 1: Wood Burner

Solar Wiring by Other.

All units require 3 amp 230vac fused spur for controls.

All units require 16 amp 230vac double pole isolated spur for backup immersion heater.

Wiring for Heat Exchanger Pump, for DHW.

Factory fitted and wired, on two Heat Bank thermal stores.

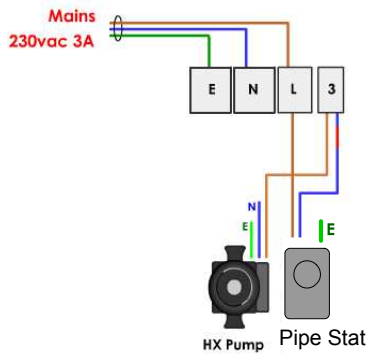

Wiring for Wood Burner Pump and Solar Controller.

Pump is fitted to Heat Bank, Controller supplied loose.

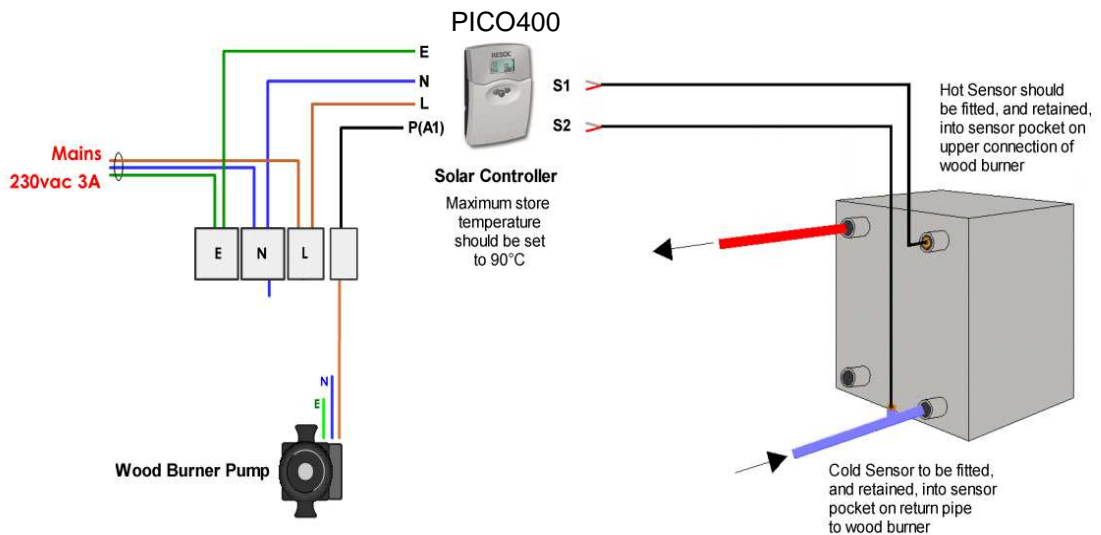

Morden Hall Contract

Contract 31554

SYSTEM 2: Heat Pump

Solar Wiring by Other.

All units require 3 amp 230vac fused spur for controls.

All units require 16 amp 230vac double pole isolated spur for backup immersion heater.

